





ITEM NO.	PART NUMBER	Description	QTY.
1		TITAN OUTER RACE	1
2		OUTER HOUSING	1
3		TITAN INNER RACE	1
4		MAIN SHAFT	1
5		HI TEMP O RING 	2
6		RETAINING RING	1
7		HI TEMP O RING 	1

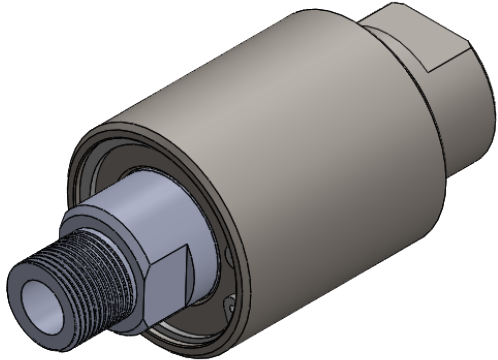
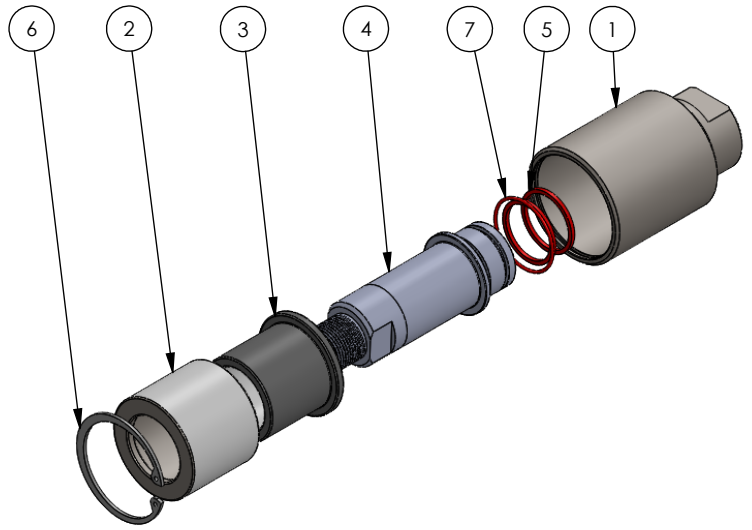
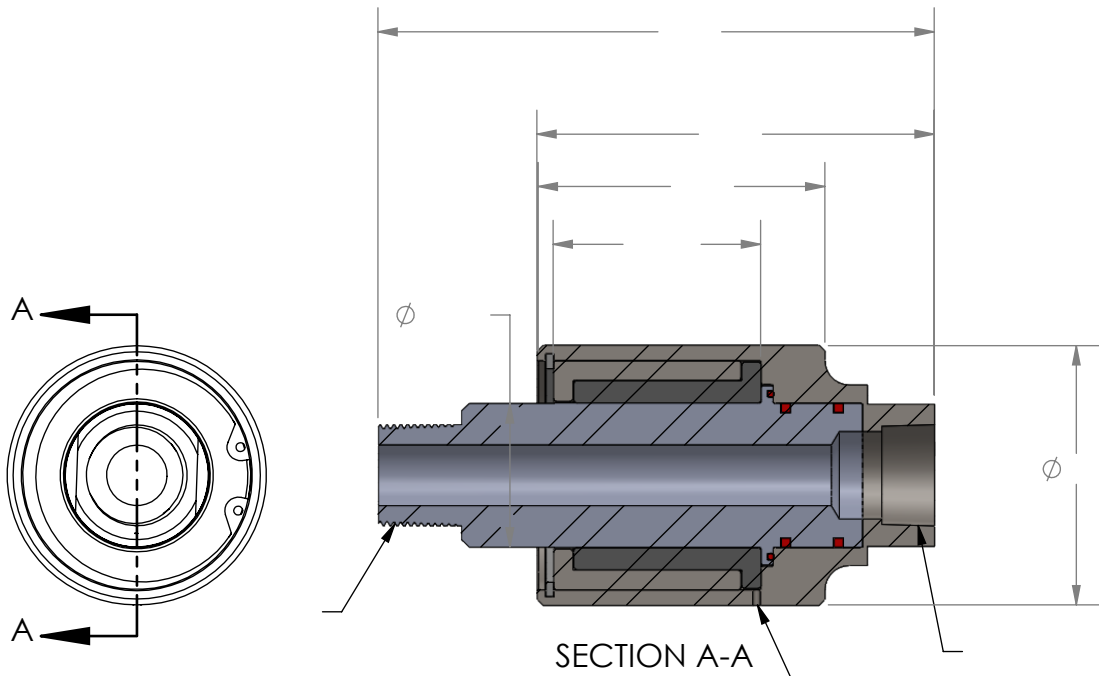

CASTER COOLING ROTARY JOINT

SIZE	PART NO.	REV
<b>A</b>		

JOB		QTY		TOLERANCES UNLESS OTHERWISE SPECIFIED		MATERIAL TITAN	
				INTERPRET GEOMETRIC TOLERANCING		FINISH	
				 THIRD ANGLE PROJECTION		STATUS:	
PROPRIETARY AND CONFIDENTIAL THE INFORMATION CONTAINED IN THIS DRAWING IS THE SOLE PROPERTY OF TITAN BEARINGS. ANY REPRODUCTION IN PART OR AS A WHOLE WITHOUT THE WRITTEN PERMISSION OF TITAN BEARINGS IS PROHIBITED.				DRAWN CHECKED		NAME DATE 07/18/17	